

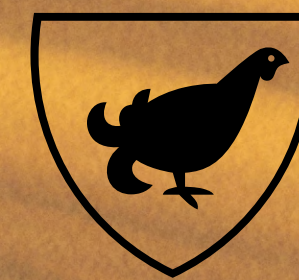

ORREFORS



NEW Product Introductions

# Top 10 Collections

Here you will find our most beloved Orrefors collections of 2023! Immerse yourself with timeless designs and impeccable craftsmanship.



1. Carat



2. Intermezzo



3. City



4. Annual Ornament



5. Heart



6. Erik



7. More

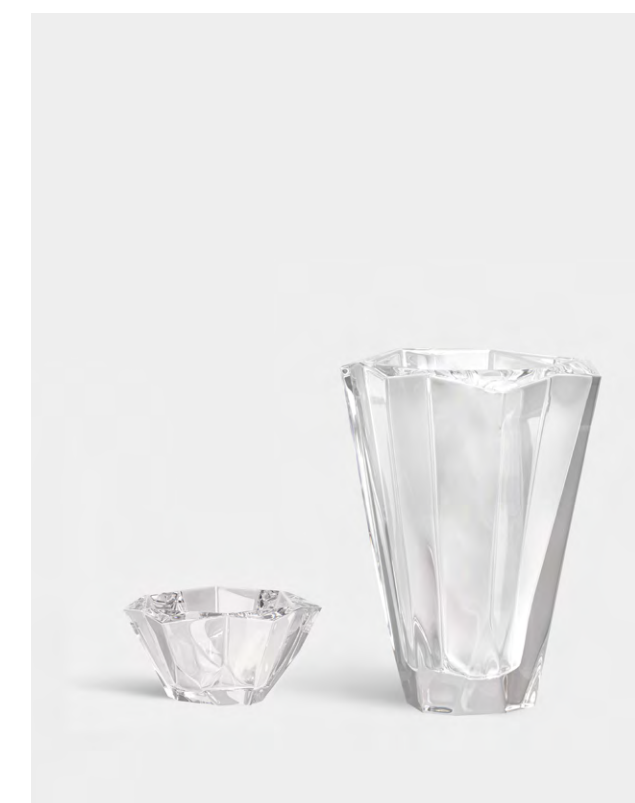

8. Precious



9. Street



10. Peak

# Recognition

Awards

# Reed



ORREFORS 

## Red Dot Award

Product Design

"The Red Dot Award is fantastic international recognition for Reed as a design and Orrefors' product expertise in interior design. It's absolutely vital that Swedish design continues to make headway internationally and this award provides Reed with a great development platform going forward," says Monica Förster who was recently named Architektur & Wohnen 'AW Designer of the Year 2023'.

The Red Dot Design Award is a premier global design competition, celebrating outstanding creativity and innovation across various industries.



reddot winner 2023



# Recognition

Awards

Tou



ORREFORS 

## iF Design Award

Home Furniture/Decoration

Tou by Orrefors is a collaboration with renowned Swedish design studio Claesson Koivisto Rune. The collection – two votives and one hurricane lamp – is made in a two-part design that combines functionality and minimalistic lines.

The IF Design Award, originating from Germany, is a highly prestigious global recognition for outstanding design achievements, setting the standard for innovation and excellence across industries.



# Recognition

Awards

## Intermezzo Gold

### TableWare International Award of Excellence

Fine Glassware

Intermezzo Gold by Erika Lagerbielke.

The TableWare International Awards highlight innovation and excellence in tableware design, celebrating creativity in the field.



# Swedish Craftsmanship Since 1898

Orrefors has always been about looking ahead. In search of new techniques, expressions, forms – and designers. Curious to discover more of the endless possibilities of glass.

From the very beginning, our signature has been to bring together traditional craftsmanship with contemporary visionaries. Combining history with the present – to shape the future. This formula has resulted in some of our greatest successes.

As we continue our journey, we're dedicated to expanding our reach and engaging with a wider audience. Alongside relaunching select pieces from our extensive catalog, we're actively forging new partnerships with leading designers. Join us as we push the boundaries of glass and design, creating iconic products that will resonate with future generations. Welcome to the evolving world of Orrefors.



## 5 reasons why you should work with Orrefors

- Large inventory in the US with a quick turnaround time
- Award-winning elegant Scandinavian design
- Heritage since 1898; our experience spans more than 7 generations
- Our renowned designers create elegant products for retail, museums, art galleries, and special projects
- Sustainability - One of the leading sustainable factories in Europe and one of the first to remove lead from our own production back in the 1970s

---

Orrefors has been established in Swedish design tradition since 1898, characterized by timeless aesthetics, functionality, craftsmanship, and sustainable quality. Orrefors offers premium products designed by well-known designers for an audience interested in Scandinavian design. The glass and shape are always in focus, combined with elegance, simplicity, and confidence.

Even though the holding company is placed in Kosta, Sweden, the daughter company has expanded in the US. Therefore, we have built a significantly large inventory in our warehouse. You can also visit our showroom at 41 Madison in New York, to see our beautiful products. Our elegant products are designed by well-known artists and designers, like Lena Bergström who is behind

the best-selling collection Carat and Ingegerd Råman, whose elegant style continues to be an objective for the future.

Orrefors produces products considered award-winning Scandinavian designs, therefore many of our collections have received awards for Excellent Swedish Design like Merlot in 1995, Puck in 1999, and Celeste candlesticks in 1992.



# Sustainability

Our goal is to create timeless and elegant glass for everyday use, as well as design objects that last from one generation to the next - exactly as we've been doing since 1898. Orrefors glass constitutes sustainable design that creates a more beautiful world.

---

## Our glass

At Orrefors, our legacy of innovation extends back to the 1980s, when we transitioned to non-leaded glass at Kosta Glassworks. This commitment to sustainability has remained steadfast, culminating in our goal to ensure all partner factories followed suit by 2019. As we unveil our cherished 2024 collections, each piece embodies our dedication to pioneering craftsmanship and environmental responsibility.

## Transportation

When choosing how to transport our products to, from, and within Sweden, we always keep the environment in mind. To the extent possible, we ship by sea rather than by road or air, and we make sure to pack the vehicles or containers completely to reduce the number of transports. We continuously test our products that are intended for contact with food, to ensure the glass does not transfer any substances to the food.

## People

Just like us, all of our partners within and outside the EU must comply with our Code of Conduct, which ensures fundamental working conditions, the right to form trade unions, regulations for minimum pay, overtime pay, and limits to working hours. The Code of Conduct also includes bans on child labor and discrimination. We visit our suppliers annually to ensure high quality and compliance with these rules. The majority of our partnering factories are in the EU.

## Our goals for a better world

At the Kosta Glassworks in the south of Sweden, we constantly work on refining the production of our main material – glass. As part of our improvement initiatives, we are currently working with four of the UN's Global Goals: clean water and sanitation, affordable and clean energy, innovation and infrastructure, and responsible consumption and production. At the glassworks in Kosta, we have our own treatment plant, and we reuse the water in the production process as much as possible. We also work with energy-saving measures such as efficient lighting, carbon-neutral ovens, and district heating for our premises. We always want to find new solutions and therefore partner with different institutions and universities. We are currently working with the research institute RISE on a project to look at process optimization to achieve the best possible glass quality. All waste from the production of clear glass at Kosta Glassworks is reused to make new glass, saving both natural resources and energy.

## Our vision for the future

We're constantly working on improving the production of elegant, innovative design that contributes to a more sustainable world for centuries to come.



# Content & Digital Assets

Inspirational assets have never been more crucial

## New Imagery

Throughout the year our marketing team's primary focus has been to implement the new Orrefors graphic profile into all channels. Along with photographers, we have developed new conceptual images and videos to share with you. Not only do we have new beautiful product shots, but also environmental images as well as lifestyle shots in real settings. You can view them on our website, and download them easily from our Asset Bank <https://okb.assetbank-server.com/>.

## New Copy

We are continuously updating our copy and making it more modernized; both on product level as well as collection level. You can already see this on our website and this material will also be available for you to use on your own website/marketing material. Please reach out to our customer service team at [customercare@orrefors.us](mailto:customercare@orrefors.us) for our updated copy texts.

## Current collections that have received new imagery

- Informal
- Squeeze
- Carat
- Legend
- Pulse
- Tou
- Cut In Number
- Raspberry
- Bloom
- More



# Orrefors New Arrivals SS24

# Claesson Koivisto Rune

## About the designer

Claesson Koivisto Rune is a Swedish architectural firm founded in 1995 by Mårten Claesson, Eero Koivisto, and Ola Rune – all of whom studied at one of Sweden’s most prestigious art and design universities. Over time, they have come to work broadly with architecture and design, and they have, in various interior design projects, created furniture and buildings such as the interior for Inde/Jacobs Gallery in Marfa, Texas. They have also designed products for more than 80 international brands, such as Studio TK and Fontana Arte.

During the years, Claesson Koivisto Rune has won over 60 awards and distinctions, including Designer of the Year and Best Seating from Elle Deco Italia 2014, Furniture of the Year from Elle Deco Sweden 2012, and Designer of the Year from Elle Deco Sweden 2011. They also received the Prince Eugen Medal for outstanding artistic achievement in architecture from King Carl XVI Gustaf of Sweden in 2020.

## Previous collections by the designer



Ebon



Tou

# Midsummer

## Design Claesson Koivisto Rune

Midsummer may well be the most appreciated holiday in Sweden, with celebrations dating back to the Middle Ages. A fond custom dictates picking seven kinds of flowers and placing them under your pillow on Midsummer's Eve. As twilight's magic unfolds, your future partner shall be revealed in the realm of dreams.

Seeing the importance of the holiday, renowned designer trio Claesson Koivisto Rune and Orrefors have teamed up to create a collection of seven mini vases, inspired by wild flowers. While each of the seven vases has its own distinct character, they're also designed to group brilliantly, with one complementing the other. Design by Claesson Koivisto Rune.

- Collection of mini vases offering flexible styling options, whether used alone or combined creatively
- Sleek and minimalist aesthetic that complements any interior style
- Ideal for showcasing a single stem or a few flowers
- Adds a touch of effortless sophistication to your home
- Distinct silhouettes for high recognition
- Great storytelling with the connection to Swedish Midsummer
- Collectible Appeal: Opportunity for collectors to curate a stunning ensemble

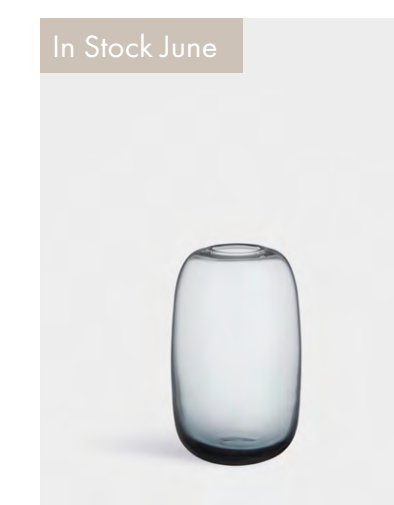

**NEW 6722402**  
Midsummer Vase  
Oxeye Daisy Mini  
H 3.7" W 2.2"  
**\$65**

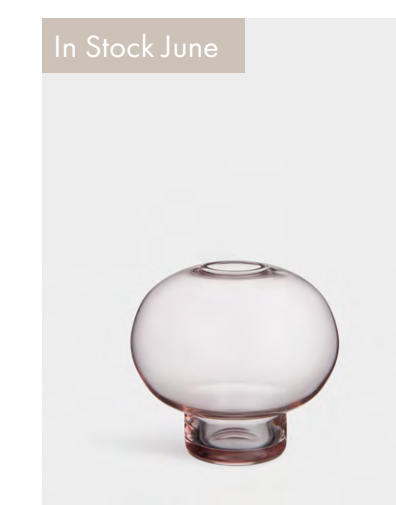

**NEW 6722403**  
Midsummer Vase  
Red Clover Mini  
H 3.2" W 3.5"  
**\$65**

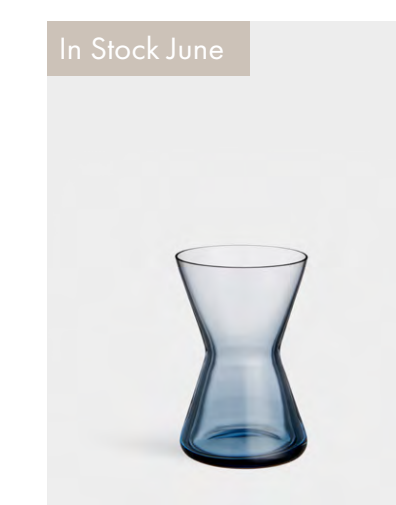

**NEW 6722405**  
Midsummer Vase  
Peach-leaved Bellflower Mini  
H 3.4" W 2.3"  
**\$65**

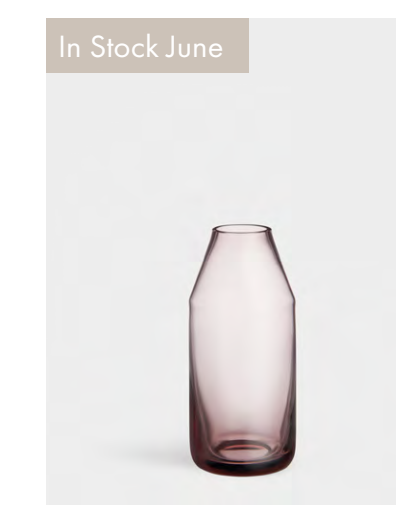

**NEW 6722406**  
Midsummer Vase  
Wood Cranesbill Mini  
H 3.9" W 1.7"  
**\$65**

# Midsummer

## Design Claesson Koivisto Rune

Midsummer may well be the most appreciated holiday in Sweden, with celebrations dating back to the Middle Ages. A fond custom dictates picking seven kinds of flowers and placing them under your pillow on Midsummer's Eve. As twilight's magic unfolds, your future partner shall be revealed in the realm of dreams.

Seeing the importance of the holiday, renowned designer trio Claesson Koivisto Rune and Orrefors have teamed up to create a collection of seven mini vases, inspired by wild flowers. While each of the seven vases has its own distinct character, they're also designed to group brilliantly, with one complementing the other. Design by Claesson Koivisto Rune.

- Collection of mini vases offering flexible styling options, whether used alone or combined creatively
- Sleek and minimalist aesthetic that complements any interior style
- Ideal for showcasing a single stem or a few flowers
- Adds a touch of effortless sophistication to your home
- Distinct silhouettes for high recognition
- Great storytelling with the connection to Swedish Midsummer
- Collectible Appeal: Opportunity for collectors to curate a stunning ensemble

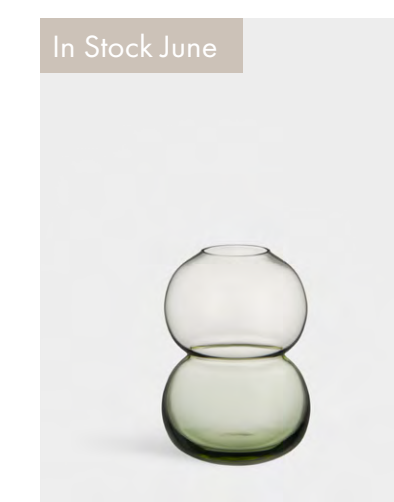

**NEW 6722400**  
Midsummer Vase  
Cow Vetch Mini  
H 3.5" W 2.5"  
\$65

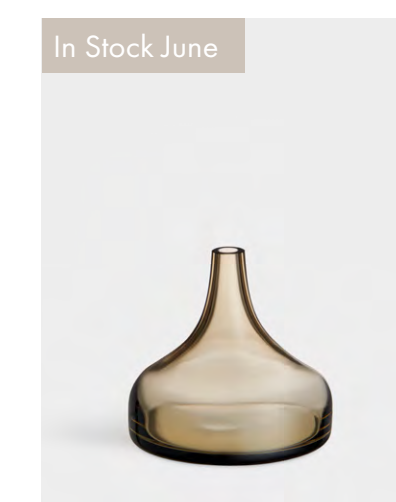

**NEW 6722401**  
Midsummer Vase  
Water Avens Mini  
H 3.2" W 3.5"  
\$65



**NEW 6722404**  
Midsummer Vase  
Bird's-foot Trefoil Mini  
H 3.5" W 3.0"  
\$65

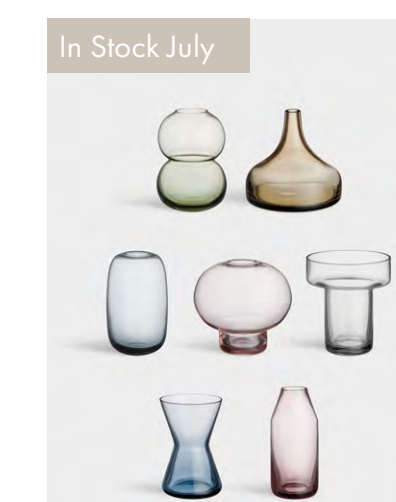

**NEW 6722407**  
Midsummer Mini Vases  
Set of 7  
\$395

# Assets



# Assets



# Ingererd Råman

## About the designer

Ingegerd Råman (born in Stockholm in 1943) studied at Carl Malmsten's Capellagården, Öland, at the University of Arts, Crafts & Design in Stockholm and at the Istituto Statale d'Arte per la Ceramica in Faenza, Italy.

In 1967, Råman started her own ceramics studio in Skåne and throughout her career, she has worked as both a ceramics and glass designer. Ingegerd Råman's designs have earned multiple Swedish Design Awards, and her work is represented at the Nationalmuseum in Stockholm, the Riihimäki Glas Museum in Finland and the Victoria & Albert Museum in London. Råman is among Orrefors' most influential designers with an elegant style that remains a future benchmark.

For Orrefors, Ingegerd Råman has designed the collections Cut In Number, Lumiere, Pond and more.

## Previous collections by the designer



Cut In Number



Lumiere



Pond



# Pulse

Design Ingegerd Råman

The Pulse collection from Orrefors, with its crisp, distinctive lines, complements both beverages and table arrangements splendidly. Crafted with precision, each glass embodies a harmonious blend of Scandinavian sophistication and modern allure. Design by Ingegerd Råman.

- A modern classic
- Elevates the wine-drinking experience
- Bubble Point in the champagne glass, which enhances the bubbles from the champagne
- Boasts lasting quality that ensures durability and reliability with every use
- A stylish addition to any table setting or home bar
- Perfect for both everyday use and special occasions
- Dishwasher safe



**NEW 6295321**  
Pulse Champagne 9.5 oz  
Set of 4  
H 8.7" W 2.8"  
**\$75**



**NEW 6295319**  
Pulse White Wine 13.0 oz  
Set of 4  
H 7.9" W 3.1"  
**\$75**

# Pulse

Design Ingegerd Råman

The Pulse collection from Orrefors, with its crisp, distinctive lines, complements both beverages and table arrangements splendidly. Crafted with precision, each glass embodies a harmonious blend of Scandinavian sophistication and modern allure. Design by Ingegerd Råman.

- A modern classic
- Elevates the wine-drinking experience
- Boasts lasting quality that ensures durability and reliability with every use
- A stylish addition to any table setting or home bar
- Perfect for both everyday use and special occasions
- Dishwasher safe

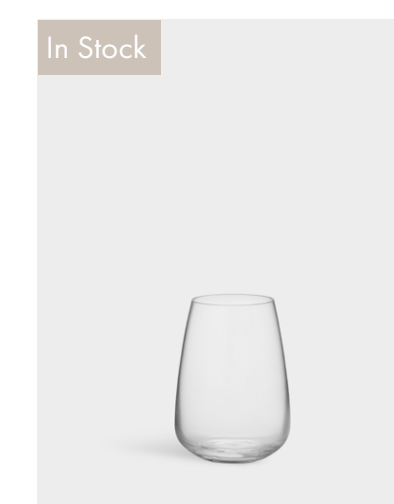

**6295304**  
Pulse Stemless 11.5 oz  
Set of 4  
H 4.2" W 3.1"  
**\$75**

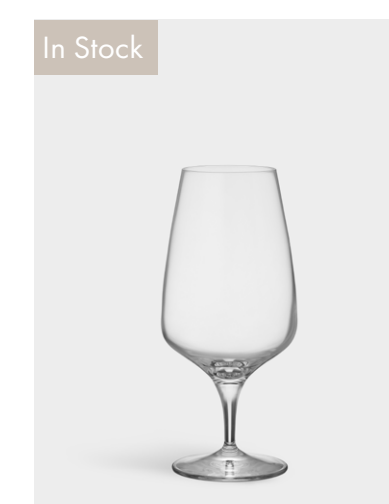

**6295303**  
Pulse Beer 18.5 oz  
Set of 4  
H 7.75" W 3.5"  
**\$75**

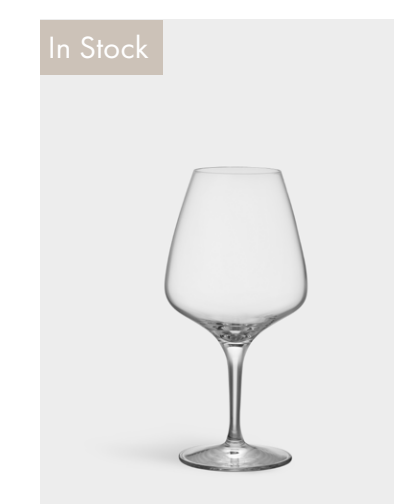

**6295302**  
Pulse Wine 15.5 oz  
Set of 4  
H 7.6" W 3.75"  
**\$75**

# Assets



# Erika Lagerbielke

## About the designer

Erika Lagerbielke (born 1960) studied at the University of Arts, Crafts & Design in Stockholm with a focus on industrial design. She is a professor of design at Linnaeus University, where she works with education and research in areas including the artifacts and culture of the meal, dining environments as generators of value, and the sustainable development of glass.

Lagerbielke began her collaboration with Orrefors in 1982, during her studies at the University of Arts, Crafts & Design, and had her major breakthrough with the Intermezzo series already in 1984. Her most acclaimed special projects include the wedding gift to Crown Princess Victoria and Prince Daniel Westling from the Swedish Parliament and government in 2010, Linnaeus University's vice-chancellor chain in 2010, Hook of Sigrid for the Diocese of Växjö in 2011, and a special set for Michelin restaurant Operakällaren in Stockholm in 2020.

## Previous collections by the designer



Intermezzo



Enjoy



Metropol



More



Difference



# More

## Design Erika Lagerbielke

Inspired by and built on insights from professional restaurateurs, More is a collection by Orrefors equally appreciated in star restaurants and at family dinners. The More Bistro is a small wine glass with a rounded shape that provides a generous wine experience. It's ideal for occasions when you want to treat yourself to a glass of wine in all simplicity, for example at lunch. Design by Erika Lagerbielke.

- Relaxed, inclusive, and inviting
- Equally appreciated in high-end dining environment as home settings
- Bubble Point in the champagne glass, which enhances the bubbles from the champagne
- Creates an elevated everyday drinking experience
- Embodies exceptional quality and functionality
- Dishwasher safe



**NEW 6312418**  
More Bistro Wine 10.5 oz  
Set of 4  
H 6.8" W 3.1"  
**\$75**

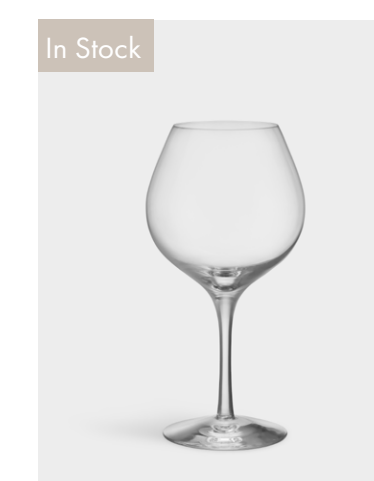

**NEW 6314416**  
More Pinot 20.3 oz  
Set of 4  
H 8.2" W 4.2"  
**\$75**

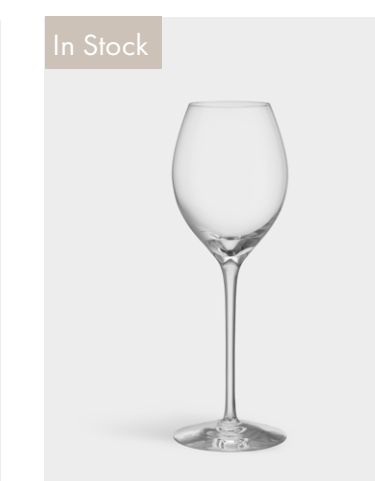

**NEW 6314415**  
More Champagne Boule 10.5 oz  
Boule Set of 4  
H 9.1" W 3.1"  
**\$75**



**6310155**  
More Martini 6.4 oz  
Set of 2  
H 6.7" W 3.9"  
**\$50**

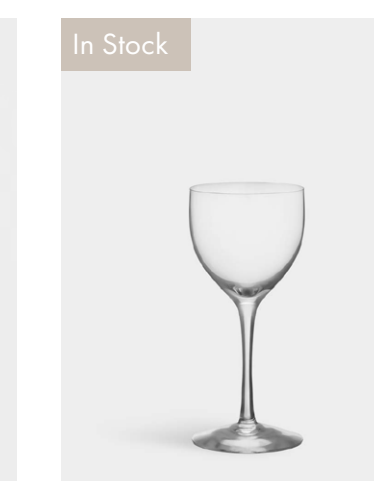

**6310160**  
More Nick & Nora 5.7 oz  
Set of 2  
H 6.3" W 2.8"  
**\$50**



Click for Product Video

# More

Design Erika Lagerbielke

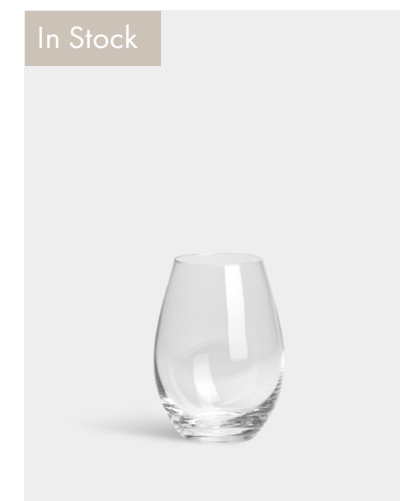

**6310103**  
More Tumbler 13.0 oz  
Set of 4  
H 4.6" W 3.3"  
**\$75**

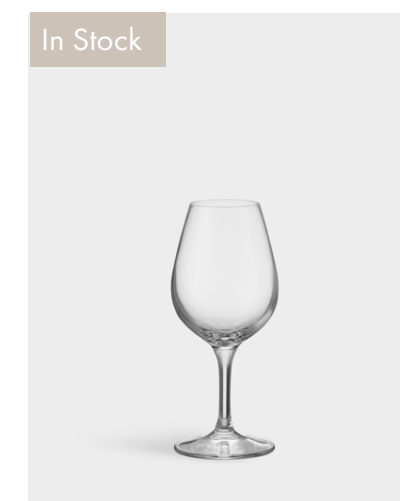

**6310124**  
More Spirits 7.0 oz  
Set of 4  
H 6.13" W 2.69"  
**\$65**

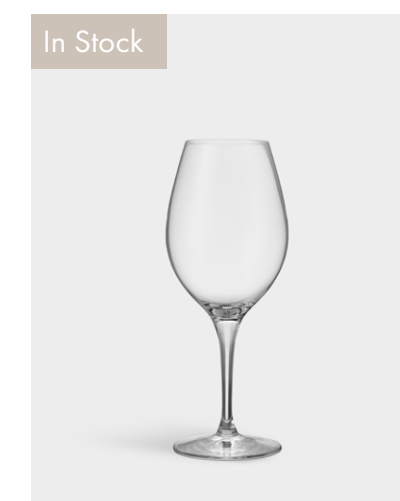

**6310102**  
More Wine 13.0 oz  
Set of 4  
H 10.0" W 4.0"  
**\$75**



**6310112**  
More Wine XL 20.0 oz  
Set of 4  
H 10.0" W 4.0"  
**\$75**

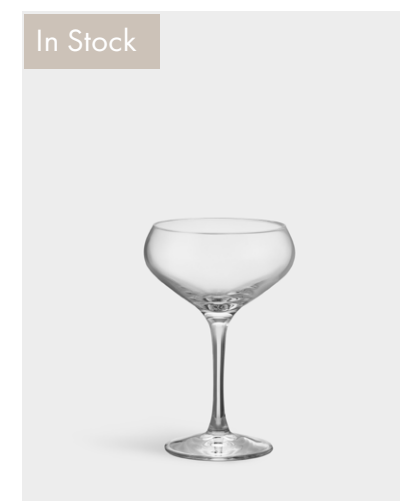

**6310103**  
More Coupe 7.0 oz  
Set of 4  
H 5.94" W 3.88"  
**\$75**

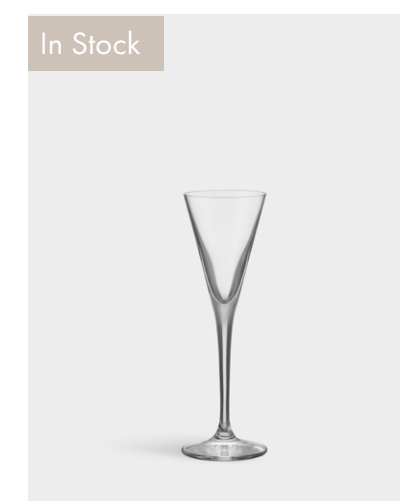

**6310153**  
More Snaps 3.0 oz  
Set of 4  
H 6.125" W 2.63"  
**\$75**

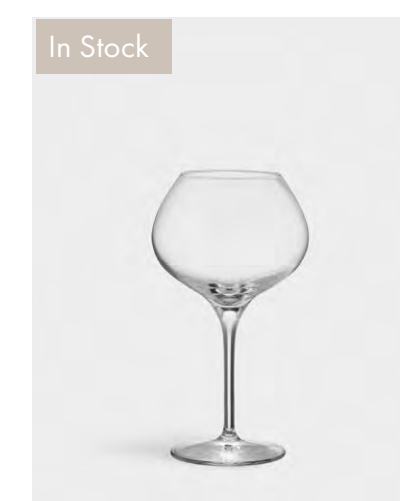

**6310123**  
More Mature 16.0 oz  
Set of 4  
H 7.69" W 4.25"  
**\$75**

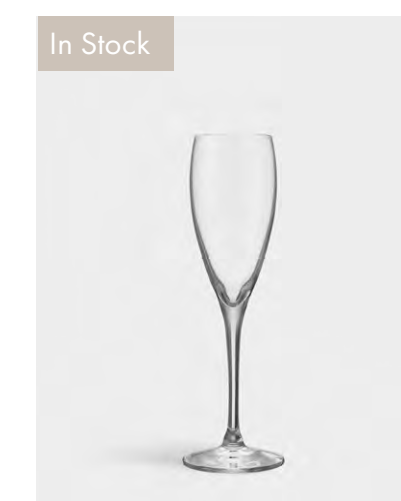

**6310101**  
More Champagne 5.0 oz  
Set of 4  
H 8.5" W 2.25"  
**\$75**

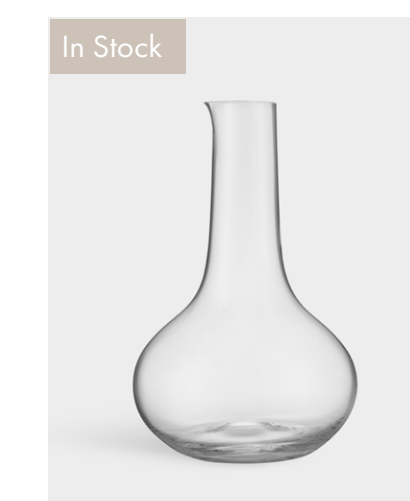

**6310188**  
More Carafe 50.0 oz  
H 9.625" W 6.125"  
**\$100**

# Assets



# Lena Bergström

## About the designer

Lena Bergström (born in Umeå in 1961) studied design in Japan, Finland, Belgium and England and has a master's degree in textiles from the University of Arts, Crafts & Design (Konstfack) in Stockholm. She began working as a designer for Orrefors in 1994 while continuing to develop in her role as a textile designer for Klässbols, Design House and Designer's Eye, among others.

Bergström's work is represented at Nationalmuseum in Stockholm, Röhsska Museum in Gothenburg, the Cleveland Museum of Art and the Victoria and Albert Museum in London. Her work has been exhibited at numerous galleries and museums worldwide and she has received many awards, including around fifteen in recognition of her glass designs for Orrefors.

In addition to product design, Lena Bergström has carried out and contributed to several interior design projects, such as Villa Björkholmen's Crystal Bar in Stockholm, the crystal reception desk at Clarion Hotel Post in Gothenburg, and the Swedish Embassy in Tokyo.

For Orrefors, Lena Bergström has designed the collections Carat (Elle Interiör Design Award 2010), Squeeze (Excellent Swedish Design 1997) and Puck (Excellent Swedish Design 1999).

## Previous collections by the designer



Carat



Squeeze



Puck





# Carat

Design Lena Bergström

The Carat collection is based on a contemporary interpretation of the traditional cut glass that has made Orrefors known around the world. The irregular geometry produces beautiful light reflections in the crystal glass. The old fashioned glass – that’s also dishwasher safe – gives anything from water to cocktails a shimmering home. Design by Lena Bergström.

- Top-selling collection
- Traditional cut glass with a modern twist
- Reflects the light in a compelling way
- Combines aesthetic appeal with functionality
- Brings a touch of glamour to any occasion
- Constant new product introductions keep the collection up to date
- Dishwasher safe

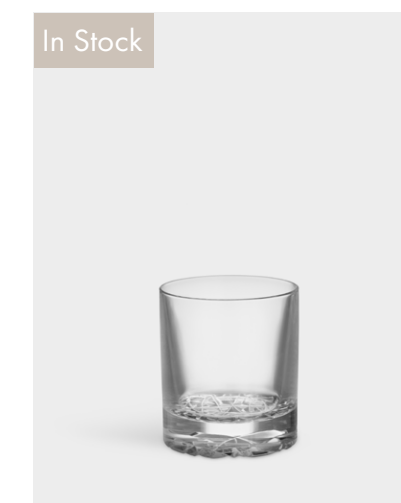

**NEW 6594117**  
Carat Old Fashioned  
Set of 4  
H 3.3" W 2.9"  
**\$170**

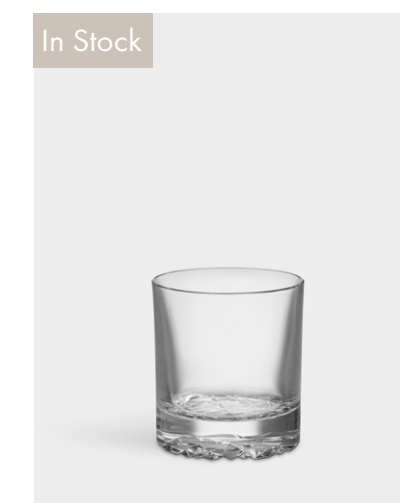

**NEW 6594118**  
Carat DOF  
Set of 4  
H 3.7" W 3.2"  
**\$170**



**NEW 6594119**  
Carat Highball  
Set of 4  
H 5.9" W 2.8"  
**\$170**



Click for Product Video

# Carat

## Design Lena Bergström

With the Carat collection, Lena Bergström diverges from the traditional ideals of cut glass. Instead she has carved out a contemporary style in which chaos and order unite to elevate the most beautiful aspects of both. This broad collection includes everything from vases, candlesticks and votives to a bowl, plate, small plate and wine glasses.

- A modern take on the cut crystal
- An expansion of our best-selling collection
- Carat Coaster Large, perfect for a wine bottle or a pillar candle
- Designed by our top designer Lena Bergström

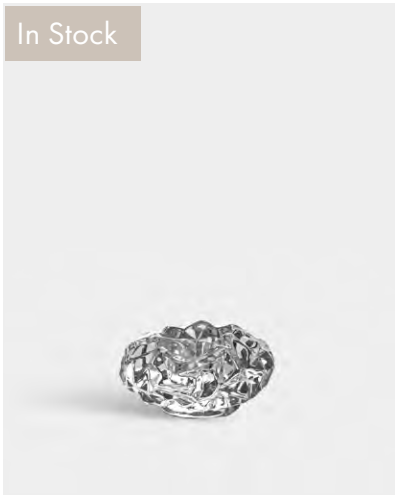

**6590161**  
Carat Votive Small  
H 2.0" W 3.8"  
**\$50**

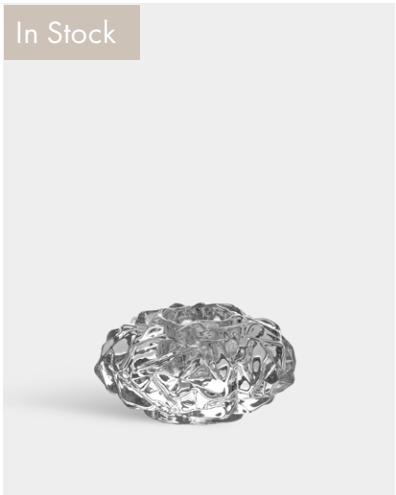

**6590163**  
Carat Votive Large  
H 2.5" W 4.8"  
**\$75**

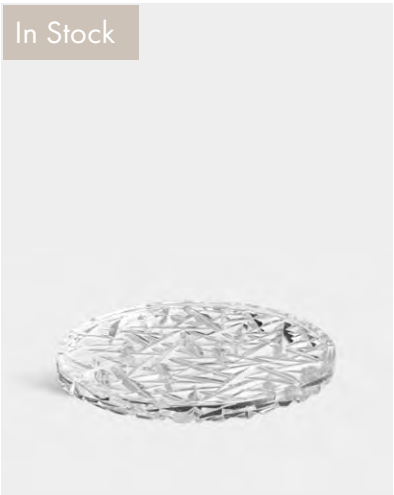

**6590105**  
Carat Coaster Large  
H 0.4" W 5.0"  
**\$50**

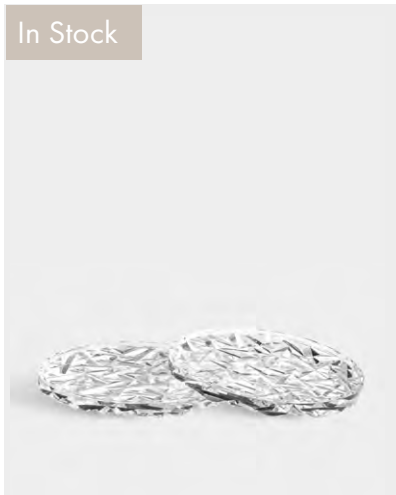

**6590103**  
Carat Coaster Small  
H 0.3" W 4.0"  
Set of 2  
**\$60**

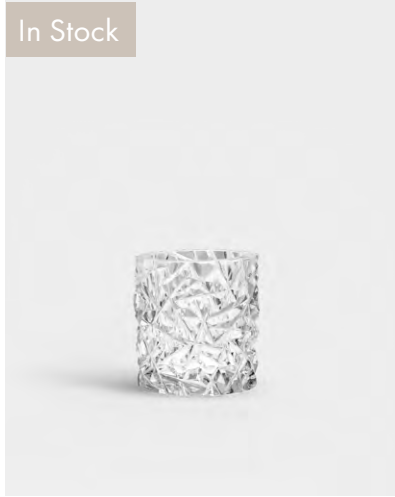

**NEW 6590171**  
Carat Candle Holder Small  
H 3.2" W 3.3"  
**\$60**

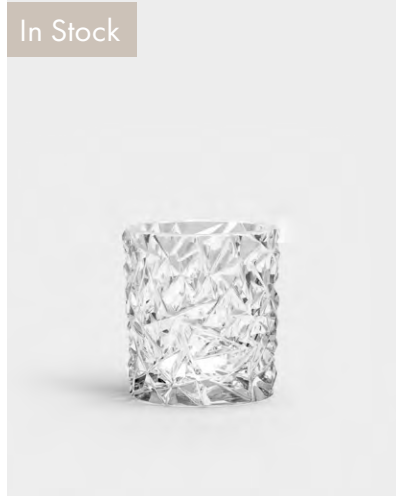

**NEW 6590172**  
Carat Candle Holder Medium  
H 3.7" W 3.4"  
**\$75**



Click for Product Video

# Carat

Design Lena Bergström

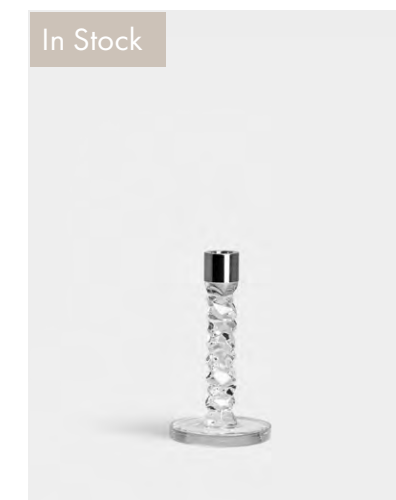

**6719396**  
Carat Candlestick  
Stainless Steel Small  
H 7.2" W 4.0"  
Set of 2  
**\$300**

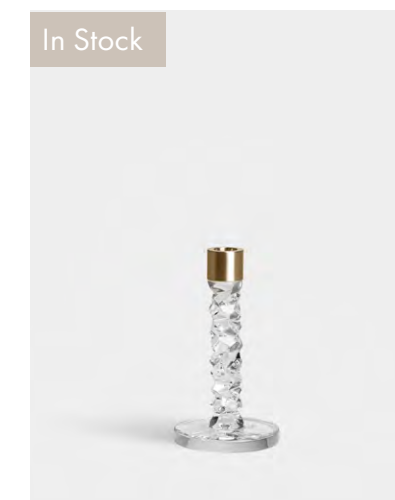

**6719895**  
Carat Candlestick Brass  
Small  
H 7.2" W 4.0"  
Set of 2  
**\$350**

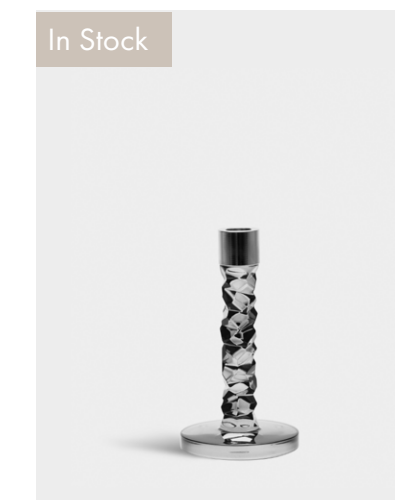

**6590173**  
Carat Candlestick Graphite  
Stainless Steel Small  
H 7.2" W 4.0"  
**\$200**

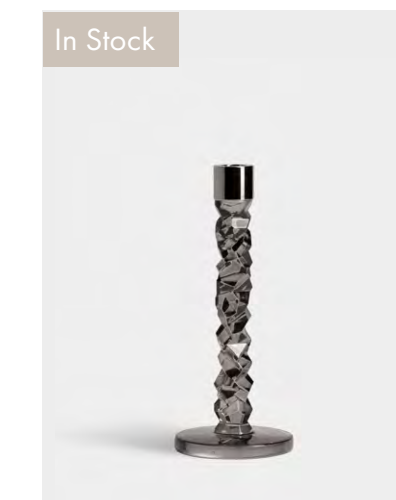

**6590170**  
Carat Candlestick Graphite  
Stainless Steel Medium  
H 9.6" W 4.0"  
Set of 2  
**\$395**

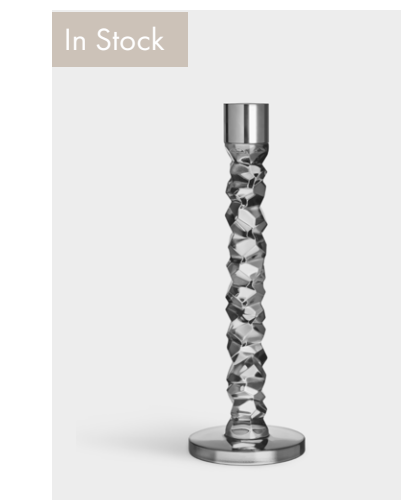

**6590174**  
Carat Candlestick Graphite  
Stainless Steel Large  
H 11.7" W 4.3"  
**\$275**

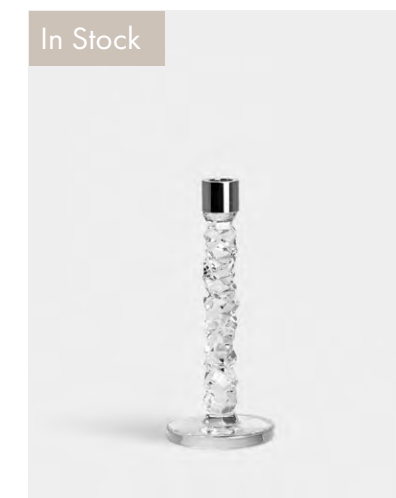

**6590162**  
Carat Candlestick  
Stainless Steel Medium  
H 9.5" W 4.0"  
Set of 2  
**\$350**



**6590166**  
Carat Candlestick Brass  
Medium  
H 9.5" W 4.0"  
Set of 2  
**\$400**

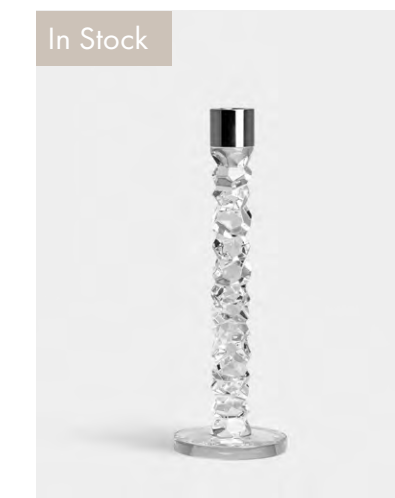

**6719397**  
Carat Candlestick  
Stainless Steel Large  
H 11.6" W 4.1"  
Set of 2  
**\$450**

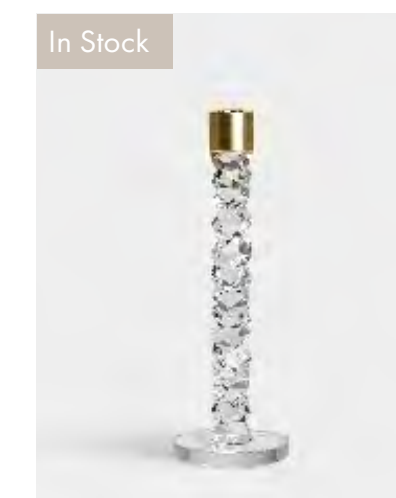

**6719896**  
Carat Candlestick Brass  
Large  
H 11.6" W 4.1"  
Set of 2  
**\$450**



Click for Product Video

# Carat

## Design Lena Bergström

With the Carat collection, Lena Bergström diverges from the traditional ideals of cut glass. Instead she has carved out a contemporary style in which chaos and order unite to elevate the most beautiful aspects of both. This broad collection includes everything from vases, candlesticks and votives to a bowl, plate, small plate and wine glasses.

- A modern take on the cut crystal
- An expansion of our best-selling collection
- Carat Coaster Large, perfect for a wine bottle or a pillar candle
- Designed by our top designer Lena Bergström



**6000024**  
Carat 3 Piece Gift Set  
**\$200**



**6590108**  
Carat Coupe 8.4 oz  
H 6.4" W 3.9"  
Set of 2  
**\$100**



**6590109**  
Carat Wine 14.8 oz  
H 8.5" W 3.4"  
Set of 2  
**\$100**



**6590100**  
Carat Champagne 8 oz  
H 9.0" W 2.8"  
Set of 2  
**\$100**



Click for Product Video



# Carat

Design Lena Bergström



**6590153**  
Carat Side Plate  
Set of 2  
H 7.5"  
**\$100**



**6590152**  
Carat Dinner Plate  
H 10.6"  
**\$55**



**6590112**  
Carat Bowl Silver Rim  
H 3.0" W 8.5"  
**\$375**



**6590124**  
Carat Vase Silver Rim  
H 9.4" W 4.0"  
**\$375**

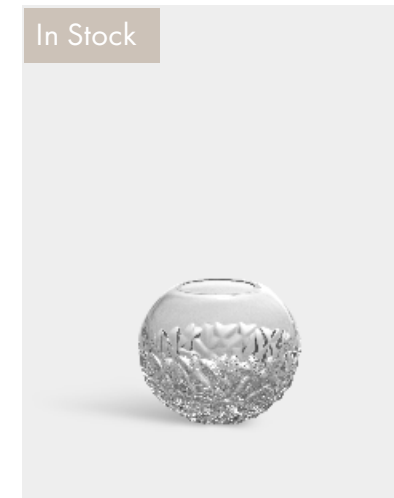

**6590120**  
Carat Globe Vase Small  
H 4.3" W 4.5"  
**\$250**

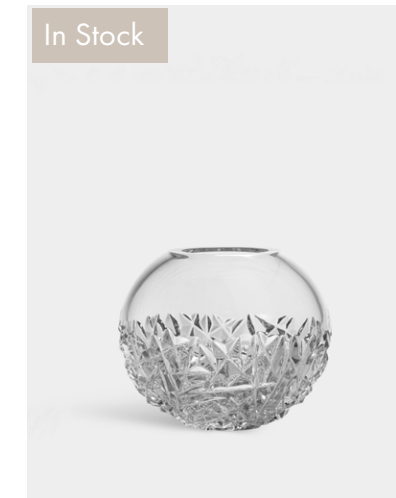

**6590125**  
Carat Globe Vase Large  
H 6.6" W 8.0"  
**\$375**

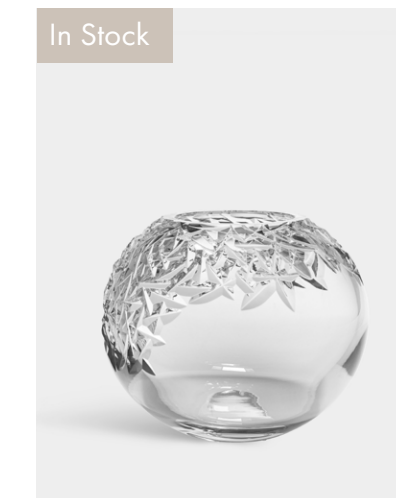

**6590133**  
Carat Globe Vase XL  
H 9.9" W 12.0"  
**\$1,450**

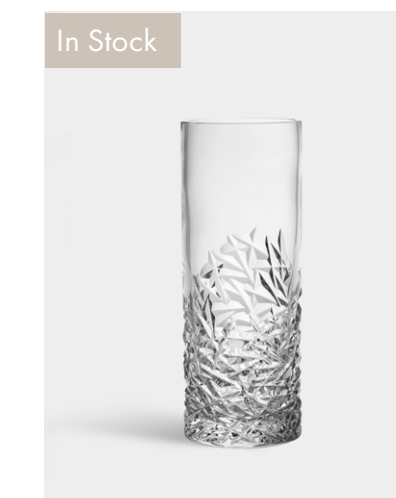

**6590131**  
Carat Vase Lower Cut  
H 14.5" W 5.5"  
**\$950**



**6590132**  
Carat Vase Upper Cut  
H 14.5" W 5.5"  
**\$950**

# Assets



# Squeeze

Design Lena Bergström

The billowing shape makes the Squeeze collection from Orrefors look unique from every angle. After the vase is blown, and while still hot, it is “squeezed” together by hand in two places. The dents form a cross inside the vase, which adds to the signature look but also holds the flowers in place. A composed and elegant large vase for use in public spaces or homes. Design by Lena Bergström.

- The unique dents provide practical functionality by holding flowers securely in place
- Elegant large vases suitable for use in a variety of settings, from public spaces to private homes
- Compelling irregularity that reflects the light and emphasizes the shape
- Elegant with or without flowers
- A size that commands attention



**NEW 6562032**  
Squeeze Vase  
Clear XL  
H 19.7" W 8.6"  
**\$600**



**NEW 6562033**  
Squeeze Vase  
Midnight Blue XL  
H 19.7" W 8.6"  
**\$600**

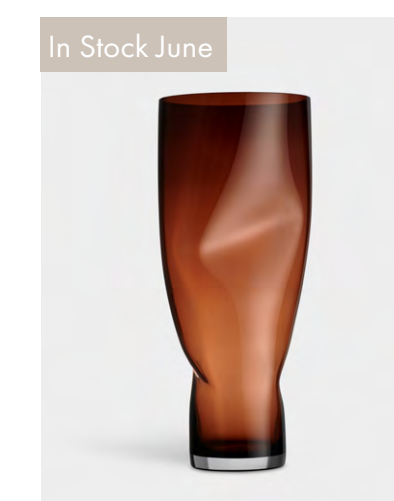

**NEW 6562034**  
Squeeze Vase  
Sunset Brown XL  
H 19.7" W 8.6"  
**\$600**

[Click for Product Video](#)

# Squeeze

## Design Lena Bergström

Like many other innovations, the idea for Squeeze arose by chance. While working on another shape entirely, Lena Bergström lost control of the heated, viscous glass, and the result was an asymmetrical inward bend. Inspired by her mistake, Squeeze was born, in which the shape has been intentionally reproduced. The “squeezed” indentations interrupt the symmetry, while simultaneously serving a clear function: flowers placed inside are neatly held together rather than spread out, even those with only a few stems.

- The unique dents provide practical functionality by holding flowers securely in place
- Elegant vases suitable for use in a variety of settings, from public spaces to private homes
- Compelling irregularity that reflects the light beautifully
- Elegant with or without flowers

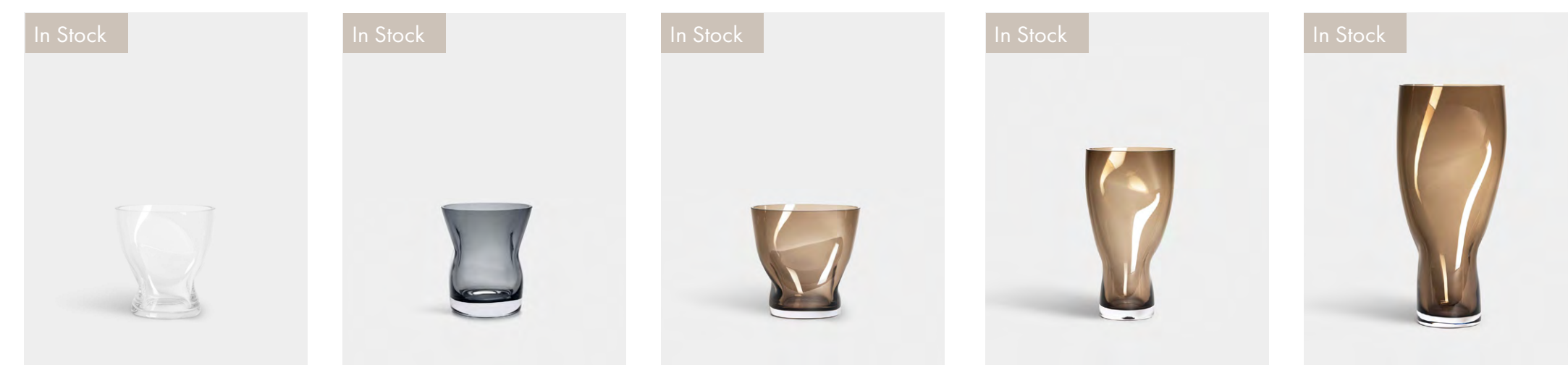

**6562030**  
Squeeze Tulip Vase  
Clear  
H 7.1" W 7.1"  
**\$200**

**6562029**  
Squeeze Tulip Vase  
Blue  
H 7.1" W 7.1"  
**\$200**

**6562031**  
Squeeze Tulip Vase  
Smokey Brown  
H 7.1" W 7.1"  
**\$200**

**6562026**  
Squeeze Vase  
Smokey Brown Small  
H 9.1" W 4.8"  
**\$200**

**6562028**  
Squeeze Vase  
Smokey Brown Tall  
H 13.4" W 5.8"  
**\$265**



[Click for Product Video](#)

# Squeeze

Design Lena Bergström

Like many other innovations, the idea for Squeeze arose by chance. While working on another shape entirely, Lena Bergström lost control of the heated, viscous glass, and the result was an asymmetrical inward bend. Inspired by her mistake, Squeeze was born, in which the shape has been intentionally reproduced. The “squeezed” indentations interrupt the symmetry, while simultaneously serving a clear function: flowers placed inside are neatly held together rather than spread out, even those with only a few stems.

- The unique dents provide practical functionality by holding flowers securely in place
- Elegant vases suitable for use in a variety of settings, from public spaces to private homes
- Compelling irregularity that reflects the light beautifully
- Elegant with or without flowers

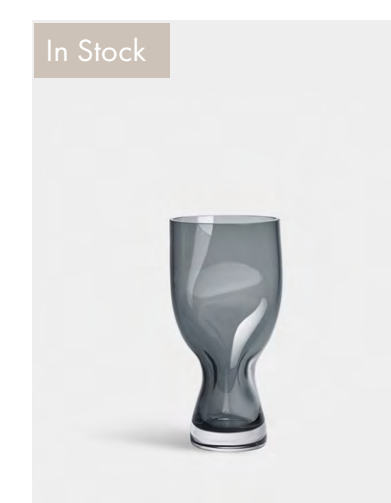

**6562021**  
Squeeze Vase  
Blue Small  
H 9.1" W 4.8"  
**\$200**

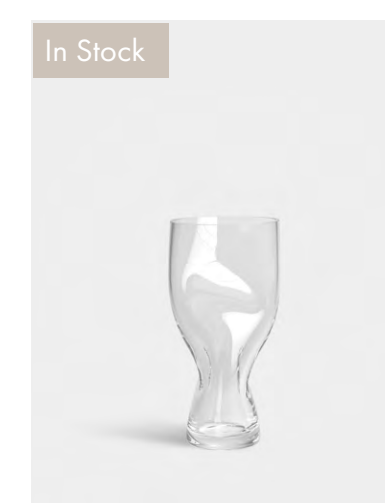

**6562022**  
Squeeze Vase  
Clear Small  
H 9.1" W 4.8"  
**\$200**

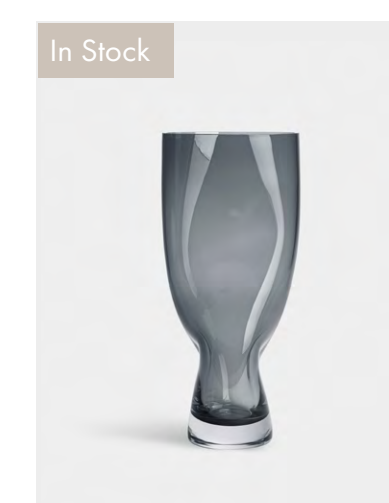

**6562024**  
Squeeze Vase  
Blue Tall  
H 13.4" W 5.8"  
**\$265**

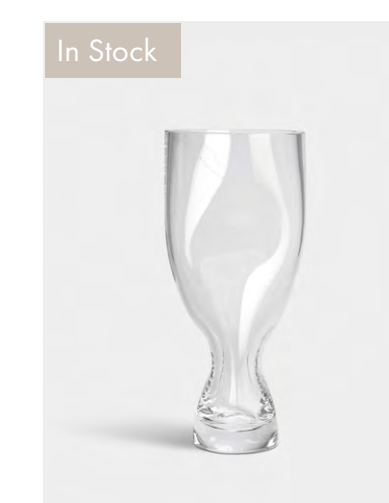

**6562025**  
Squeeze Vase  
Clear Tall  
H 13.4" W 5.8"  
**\$265**

# Assets





Click for Product Video



# Annual Holiday Ornament

## Homage Dove 2024

The Orrefors Annual Ornament is a dear tradition to us – and clearly to many more. As this year marks the 40th anniversary of its inception, it felt suitable to make it extra special. We looked back to the ornament’s first edition, to 1984, when Olle Alberius designed a crystal dove. Only right, then, that the Annual Ornament for 2024 is the Homage Dove.

- Milestone celebration: The Annual Ornament celebrates its 40th anniversary
- A homage to the original crystal Dove ornament designed in 1984
- The ornament in gold is a limited edition
- Rich tradition spanning over four decades
- Collector’s Item
- Adds timeless elegance to your holiday decor
- Hand painted in 21 K gold
- Comes in beautiful gift box

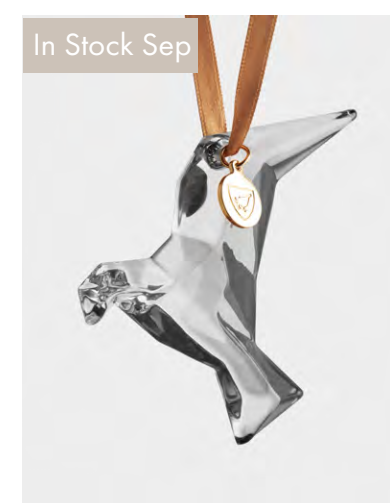

**NEW 6490833**  
Annual Holiday Ornament  
Homage Dove 2024  
H 3.9" W 3.3"  
**\$85**



**NEW 6490834**  
Annual Holiday Ornament  
Homage Dove 2024/ Limited Edition  
21K Gold  
H 3.9" W 3.3"  
**\$125**



# 1984 Edition

In the holiday spirit of pause and reflection, we looked back to the ornament's origin, more specifically the very first edition. In 1984, Olle Alberius designed a crystal dove, and it took flight right from the start. Only right, then, that the Annual Ornament for 2024 is the Homage Dove.

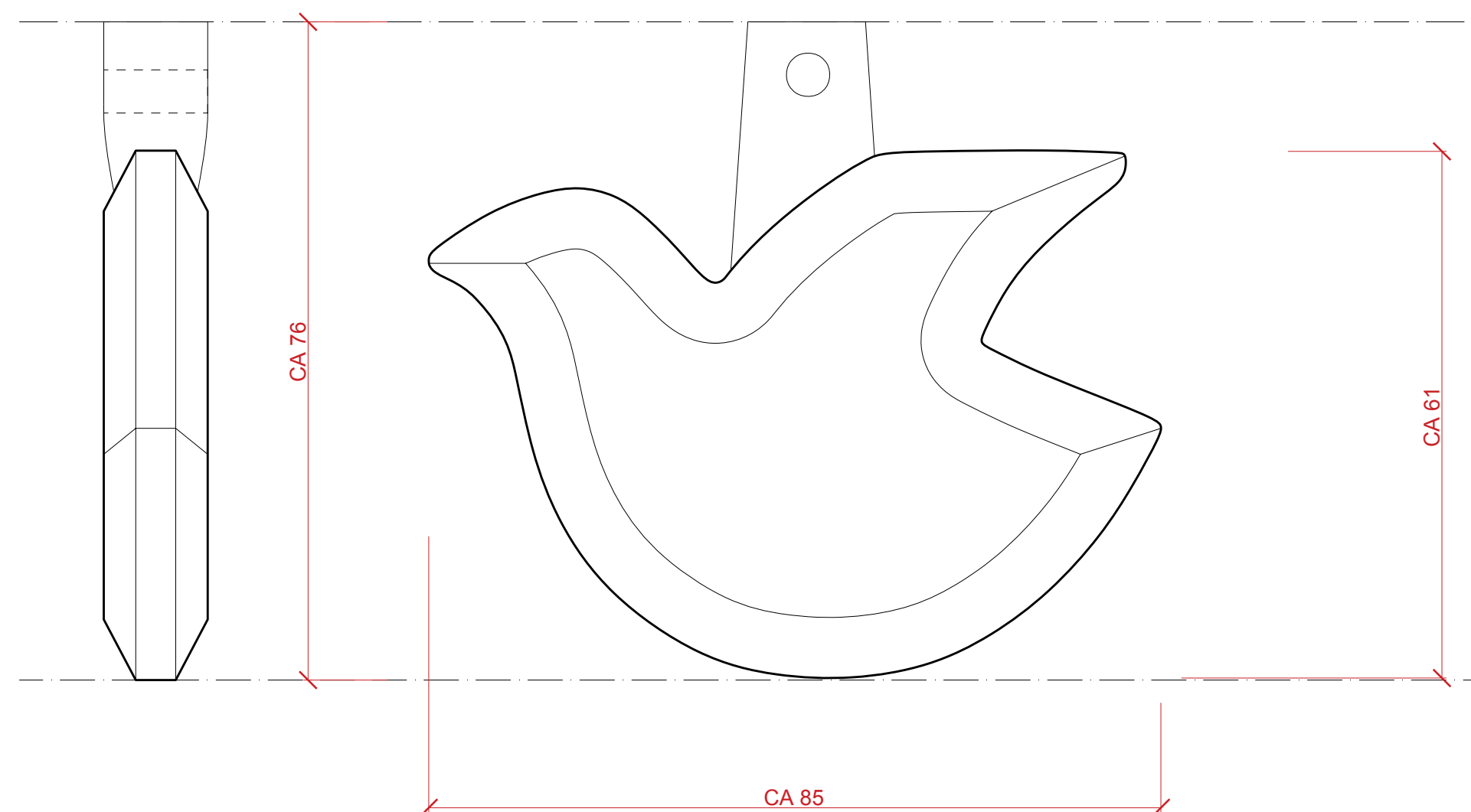

# 2024 Edition

## 40th Anniversary

This year's Annual Ornament is available in two executions – one in clear crystal glass and one limited edition hand-painted in 21-karat gold.

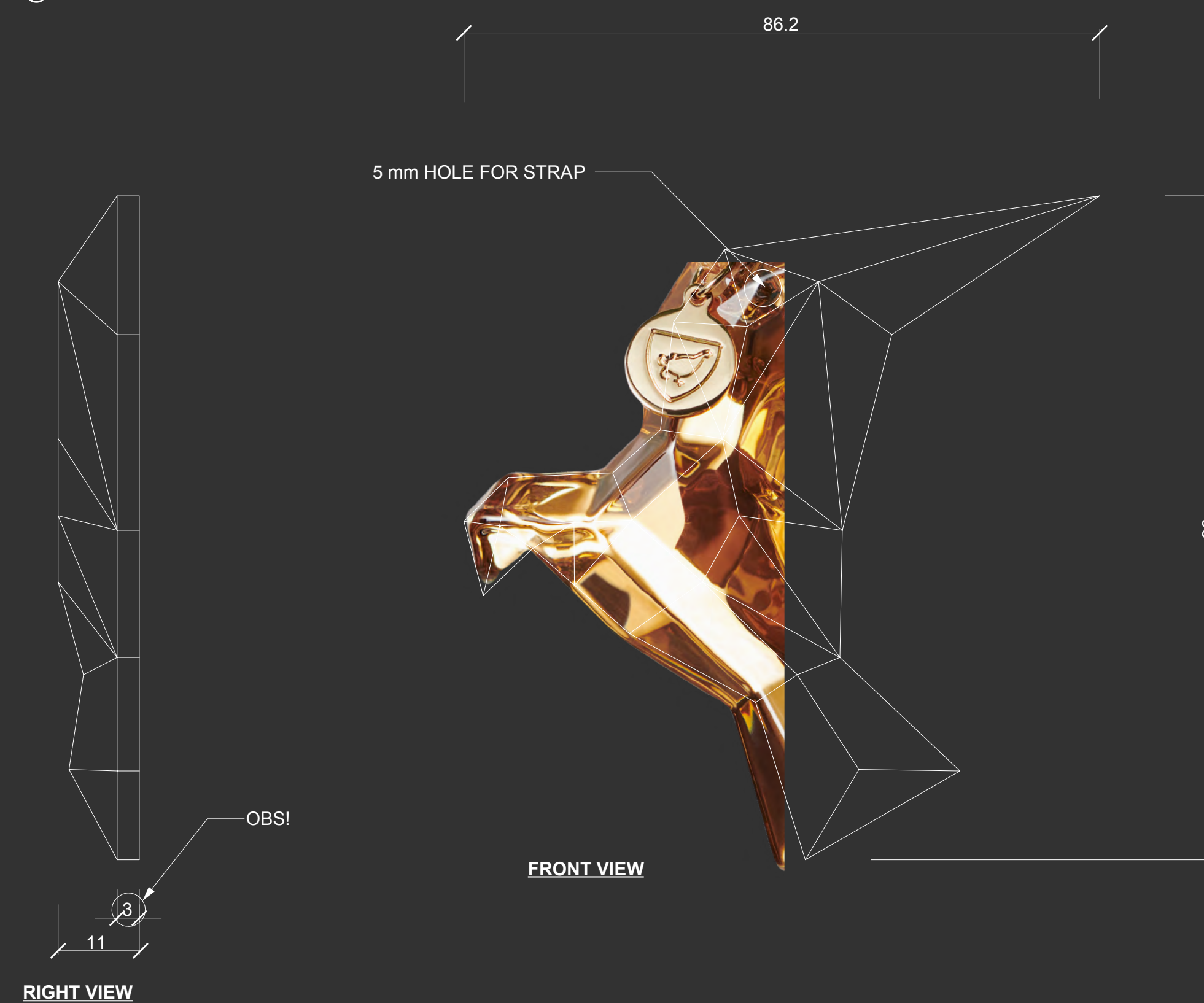

# Assets





# Monica Förster

## About the designer

Monica Förster (born 1966) is educated at Beckmans Design College and Konstfack in Stockholm and is well known for her multidisciplinary work where she combines industrial, furniture and product design with design strategy. A work that always seeks the answer to the question: "Why?". Today she runs her own studio Monica Förster Design Studio in Stockholm and collaborates in the role of creative advisor with several design brands.

Monica Förster has won the Interior Design magazine Best of Year Awards and the Good Design Award in the USA, the Best Domestic Design Wallpaper\* Design Awards in the UK and a number of other international awards. Here in Sweden, she is the only designer who has been awarded "Designer of the Year" five times.

The collection Reed is Monica Förster's first collaboration with Orrefors.

[Click for Product Video](#)

# Reed

Design Monica Förster

With Reed, Monica Förster shows how to create a sense of organic movement by emphasizing folds. A quiet swaying in the hard glass. The vase is blown in amber glass. A Red Dot Product Design winner, the collection was introduced in 2023.

- Hand-made collection
- Enhancing the natural beauty of flowers, while providing a stylish centerpiece for your home décor
- Exudes warmth and sophistication, infusing any space with a radiant glow
- Internationally acclaimed designer Monica Förster
- Red Dot Award winner 2023
- Innovative design approach that seamlessly blend form and function
- Previous colors highly appreciated among interior designers



reddot winner 2023

In Stock May



**NEW 6540907**

Reed Vase Amber Low  
H 6.9" W 8.7"

\$400

In Stock May



**NEW 6540908**

Reed Vase Amber Medium  
H 11.8" W 7.0"

\$400

In Stock May



**NEW 6540909**

Reed Vase Amber Large  
H 19.7" W 11.6"

\$1,000



[Click for Product Video](#)

# Reed

Design Monica Förster

With Reed, Monica Förster shows how to create a sense of organic movement by emphasizing folds. A quiet swaying in the hard glass. The vase is blown in amber glass. A Red Dot Product Design winner, the collection was introduced in 2023.

- Hand-made collection
- Enhancing the natural beauty of flowers, while providing a stylish centerpiece for your home décor
- Exudes warmth and sophistication, infusing any space with a radiant glow
- Internationally acclaimed designer Monica Förster
- Red Dot Award winner 2023
- Innovative design approach that seamlessly blend form and function



reddot winner 2023

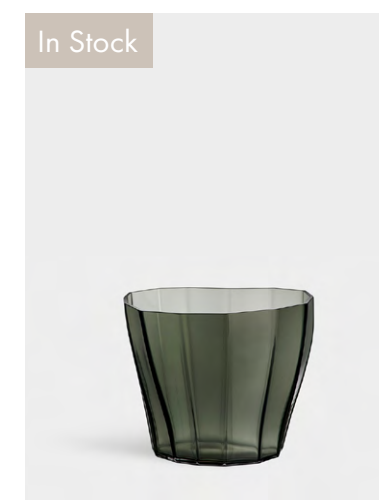

**6540904**  
Reed Vase Moss Green Low  
H 6.9" W 8.7"  
**\$400**



**6540905**  
Reed Vase Moss Green Medium  
H 11.8" W 7.0"  
**\$400**



**6540906**  
Reed Vase Moss Green Large  
H 19.7" W 11.6"  
**\$1,000**

[Click for Product Video](#)

# Reed

Design Monica Förster

With Reed, Monica Förster shows how to create a sense of organic movement by emphasizing folds. A quiet swaying in the hard glass. The vase is blown in amber glass. A Red Dot Product Design winner, the collection was introduced in 2023.

- Hand-made collection
- Enhancing the natural beauty of flowers, while providing a stylish centerpiece for your home décor
- Exudes warmth and sophistication, infusing any space with a radiant glow
- Internationally acclaimed designer Monica Förster
- Red Dot Award winner 2023
- Innovative design approach that seamlessly blend form and function



reddot winner 2023

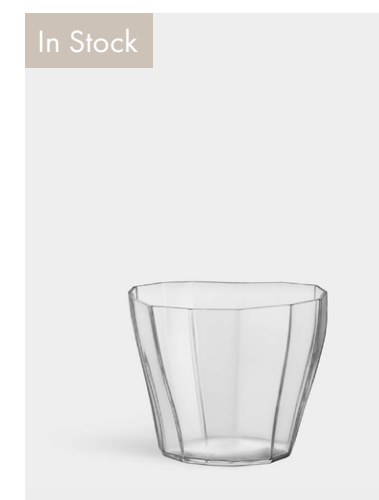

**6540901**  
Reed Vase Clear Low  
H 6.9" W 8.7"  
**\$300**



**6540902**  
Reed Vase Clear Medium  
H 11.8" W 7.0"  
**\$300**



**6540903**  
Reed Vase Clear Large  
H 19.7" W 11.6"  
**\$800**

# Assets





# Thank you!

Scan to  
download this  
presentation.

